



**IMPROVING THE ENERGY EFFICIENCY OF THE
COLD CHAIN**

FEBRUARY 2009

A BFFF PROJECT

Supported by



| | |
|--|-----------|
| EXECUTIVE SUMMARY | 3 |
| 1. INTRODUCTION | 4 |
| 1.1 Project Background | 4 |
| 2. COLD STORAGE TEMPERATURE LEGISLATION | 5 |
| 2.1 Quick Frozen Foodstuff Regulations | 5 |
| 2.2 Why set -18°C for thermal stabilisation? | 6 |
| 3. THE BENEFITS OF HIGHER TEMPERATURE | 7 |
| 3.1 The link between store temperature and evaporating temperature | 8 |
| 3.2 How much energy is saved | 8 |
| 4. DATA LOGGER TRIALS | 10 |
| 4.1 Companies and products in data logger trials | 10 |
| 4.2 Trial set up | 10 |
| 4.3 Temperature data from trials | 12 |
| 4.4 Other data collected | 14 |
| 4.5 Control of Evaporating Temperature | 14 |
| 4.6 Assessment of Energy Saving Opportunities | 15 |
| 5. SUMMARY OF PROJECT RESULTS | 16 |
| 5.1 Introduction | 16 |
| 5.2 Overall CO ₂ Savings | 16 |
| 5.3 General Findings from Host Questionnaires | 16 |
| 5.4 General Findings from Temperature Trials | 16 |
| 5.5 Specific Findings from Trials | 17 |
| 6. CONCLUDING COMMENTS | 22 |

The Carbon Trust has provided funding to the British Frozen Food Federation but is not the author of this publication or responsible for its contents. Whilst reasonable steps have been taken to ensure that the information contained within this publication is correct, the authors and the Carbon Trust, their agents, contractors and sub-contractors give no warranty and make no representation as to its accuracy and accept no liability for any errors or omissions.

EXECUTIVE SUMMARY

1. This report provides the results of a practical investigation of storage temperatures in the frozen food industry.
2. The project is aimed at identifying energy savings and the related CO₂ emission reductions related to improved temperature management in frozen food manufacturing and in cold stores.
3. The project has been managed by the British Frozen Food Federation (BFFF) with support and funding from the Carbon Trust Networks programme.
4. The investigations were carried out by Enviros on behalf of BFFF during the period June 2008 to February 2009.
5. Eight food manufacturers and five logistic service providers acted as “host sites” for the project. These represented large, medium and small companies that manufacture a wide range of frozen food products including poultry, seafood, ready meals, pizzas, vegetables, Yorkshire pudding and ice cream.
6. Data loggers were used to monitor the temperature in pallets of food held in manufacturer cold stores, being transported and then being held in cold stores belonging to logistic service providers.
7. Energy saving opportunities equivalent to 4,800 tonnes CO₂ per year were identified at the host sites. 37 specific recommendations have been made to host sites. These 37 opportunities fall into 8 groups:
 - Raising of Cold Store Air Temperature
 - Reduction of temperature difference air - refrigerant
 - Seasonal adjustment of evaporating temperature
 - Avoiding air temperature fluctuations
 - Splitting Blast Freezers and Cold Stores
 - Avoiding over-cooling in blast freezers
 - Using variable speed drive fans
 - Ensuring a flexible and effective defrost system
8. It is believed that these 8 opportunities can be replicated at many sites in the UK, including frozen / chilled food manufacturer sites and cold storage sites. This report provides descriptions of these 8 generic opportunities.
9. The lack of electricity sub-metering on refrigeration systems was identified as a barrier to the identification of good energy saving projects.

1. INTRODUCTION

The efficiency of refrigeration systems is very sensitive to the evaporating temperature – even a small temperature rise can provide useful savings. In this project the British Frozen Food Federation (BFFF) has investigated the potential to reduce energy usage and CO₂ emissions by raising the temperature control set point of cold stores and also by raising the associated evaporating temperatures.

The project involved the collection of data from 8 factories producing frozen food. In particular it included the temperature monitoring of pallets of frozen food as they are transported from a food manufacturing site to cold storage warehouses.

This report summarises the results of the temperature monitoring trials and the associated data collection from both the food manufacturers and their logistics service providers (LSPs). A total of 37 specific energy saving recommendations were made to the host companies involved in the project. These fell into 6 groups of generic recommendations which are described in this document.

1.1 Project Background

BFFF believes that many of frozen food companies have significant safety margins within their supply chain temperature controls. BFFF performed initial trials in this area during 2007. The results confirmed that “temperature inefficiency” is present and carbon emissions can be reduced, just by companies ensuring their storage facilities and processes are operating to the correct temperature tolerances.

The aim of this project was to scope the opportunity for improved temperature efficiency. This was achieved by engaging eight BFFF members to log the temperature of a range of quick frozen food products along the supply chain. Temperatures were logged from the first stage of packaging onto pallets through to the point where the product leaves the logistics cold storage warehouse.

The BFFF members selected were:

- ◆ Representative of the industry across a range of product categories from ice cream through to vegetables
- ◆ Included 1 small, 3 medium sized and 4 large companies
- ◆ Used a variety of the supply chain routes available from packaging to the point of dispatch to retailers, including logistics warehouses and direct dispatch to the retailer regional distribution centre.

Seasonality was taken into account with the trials taking place during the summer (August) and during the cooler months (October/November).

A key to the success of the project was to record representative temperatures of products moving through the supply chain. This was done with small temperature data loggers placed within boxes of frozen food stacked on pallets.

2. COLD STORAGE TEMPERATURE LEGISLATION

During the supply chain temperature monitoring, the key temperature data recorded was that of the products themselves and of the cold stores and lorries in which the products were stored in for anything between a couple of days and four weeks. The cold storage industry usually tries to achieve a cold store temperature maximum limit of -18°C, although in many cases the temperature set points are significantly lower. This section of the report provides comments about the legislation and issues around setting a maximum temperature limit.

2.1 Quick Frozen Foodstuff Regulations

Council Directive 89/108/EEC, December 1988¹, is the origin of the -18°C target for thermal stabilisation for quick frozen food (QFF). Subsequently, the UK implemented the directive through the Quick Frozen Foodstuffs Regulations in 1990, which were then updated in 2007. QFF is defined in the Quick Frozen Foodstuffs Regulations 1990² as follows:

“Quick-frozen foodstuff means a product:

(a) comprising food which has undergone a freezing process known as "quick-freezing" whereby the zone of maximum crystallisation is crossed as rapidly as possible, depending on the type of product, and

(b) which is labelled for the purpose of sale to indicate that it has undergone that process, but **shall not include ice-cream or any other edible ice”**.

The UK Quick Frozen Foodstuffs Regulations 2007³ have replaced the Quick Frozen Foodstuffs Regulations 1990, and they protect the quality of QFF as follows:

“The temperature on thermal stabilization must be -18°C or colder. This temperature must be maintained except for brief periods during transport (including local distribution) where it may reach -15°C, or when in retail display cabinets where it may reach -12°C.

Businesses must date temperature recordings and store these for at least one year or longer, depending on the nature and shelf-life of the QFF”.

In addition to food quality, the regulations specify that all new temperature monitoring instruments used in the transport, warehousing and storage of QFF must comply with European standards. The temperature data loggers used for the BFFF trials are BS EN 12830 Compliant.

¹ Council Directive 89/108/EEC of 21 December 1988

² The Quick Frozen Foodstuffs Regulations SI 1990 No:2615
www.opsi.gov.uk/si/si1990/Uksi_19902615_en_1.htm

³ The Quick Frozen Foodstuffs Regulations 2007
www.food.gov.uk/multimedia/pdfs/publication/quickfrozenguide1107.pdf

2.2 Why set -18°C for thermal stabilisation?

As outlined above, the required storage temperature set out in the Quick Frozen Food Directive is -18°C for thermal stabilisation. However, stakeholders consulted, such as major logistics operators and The Food Refrigeration and Process Engineering Research Centre (FRPERC)⁴ were not aware of why this temperature level had been selected as the maximum temperature for QFF. It is believed to be a somewhat arbitrary figure chosen simply because it is exactly equal to 0°F. Keeping to -18°C is more of a food quality issue than a food safety issue. No bacteria, mould or yeast will grow at these low temperatures.

There is potentially some flexibility in raising the temperature of Quick Frozen Food storage for particular food types. For example, meat could be stored above -18°C, based on FRPERC research^{5,6} and the quality of meat is influenced more on its preparation before freezing than the storage temperature itself. However, ice cream cannot be stored at higher temperatures as it becomes soft at -15°C and the food appearance e.g. crystallisation, might be degraded.

In terms of food quality and hygiene, the food processing that goes on before the quick freezing process has much more impact than whether the storage temperature is at -18°C or higher. This is certainly the case for meat (see FRPERC paper referred to above). However, lower storage temperatures may increase the frozen food storage life when storage times beyond 6 months are considered.

Food manufacturers often set their cold stores well below -18°C as there is the concern that the product will be exposed to warm temperatures later in the supply chain and over chilling acts as insurance. Another reason that cold stores are set lower at -20 to -22°C is so they can load shed during peak times for electricity. i.e. they over chill using cheap electricity and then let the cold store reach warmer temperatures and reduce system output during peak times.

⁴ The Food Refrigeration and Process Engineering Research Centre (FRPERC), Judith Evans telephone discussion, September 2008

⁵ *Factors influencing the Frozen Storage Life of Meats*, Judith Evans, Stephen James, University of Bristol, FRPERC

⁶ *Meat Refrigeration – Why and How?* Conference Proceedings, Organised by FRPERC and the MAFF Fellowship in Food Process Engineering on behalf of concerted action No. CT94 1881, Very Fast Chilling of Beef

3. THE BENEFITS OF HIGHER TEMPERATURE

Before discussing the actual trial results it is helpful to summarise the benefits of operating cold stores at a higher temperature.

Refrigeration systems can be thought of as equivalent to a pulley system that lifts a weight. In the case of a pulley system, the energy required to lift a given weight is dependant on the height difference between the start and finish point.

For a refrigeration plant, the “weight” is an amount of heat that must be “lifted” from a cold temperature to a warmer one. If we can reduce the **temperature lift** of a plant then the energy efficiency will improve. This is illustrated in the figure below.

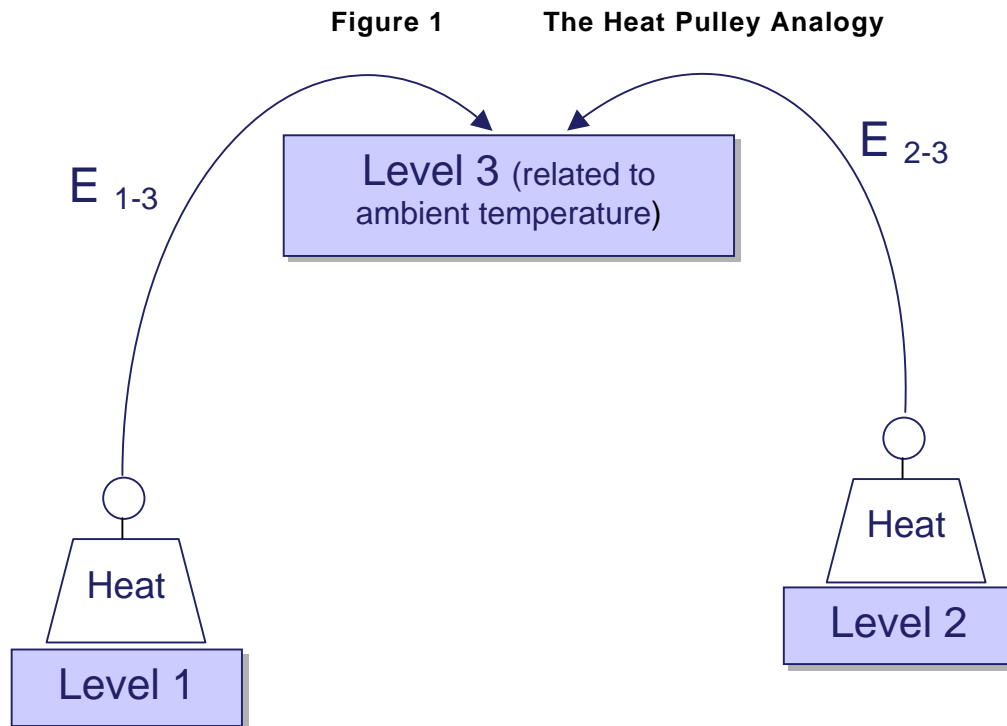

It requires less energy to move heat from Level 2 to Level 3 than it does to move heat from Level 1 to Level 3. A refrigeration plant is very sensitive to temperature lift. For a cold store, a 1deg C reduction in temperature lift will usually save about 2% to 3% of running costs.

The “heat pulley analogy” gives 2 very clear messages for the designers and operators of refrigeration equipment:

- 1) The evaporating temperature of the system should be as high as possible.
- 2) The condensing temperature of the system should be as low as possible.

There are many important opportunities to reduce condensing temperature – but they are not the subject of this investigation. This project is focussed on the possibility of raising the evaporating temperature through the operation of a cold store at a warmer temperature setting.

3.1 The link between store temperature and evaporating temperature

It is very important to recognise that the “bottom of the pulley system” is the refrigerant evaporating temperature not the cold store temperature. The evaporating temperature will always be colder than the store temperature as there needs to be a temperature difference across the evaporator. If the temperature difference is small the refrigeration plant will be more efficient. A temperature difference of about 6 deg C is indicative of an efficient plant. For a store at -20°C the evaporating temperature in a very efficient store would be around -26°C. If the temperature difference is higher it is either set conservatively (i.e. it can be easily reduced) or the store has been designed with insufficient evaporator surface area.

In some circumstances, if the store temperature is raised then the evaporating temperature will rise by an equivalent amount. However, this is not always the case. The evaporating temperature is often controlled independently of the cold store itself, especially in those situations where a blast freezer and a cold store are on a shared refrigeration system. Major inefficiency can occur in these circumstances. For example, a blast freezer may need an evaporating temperature of -40°C. If a -20°C cold store is operating on the same system it will be running 15 deg C lower than it should which uses an extra 40% energy!

3.2 How much energy is saved

A standard two stage refrigeration system of the type used by the project participants has been modelled to identify the impact of evaporating temperature (TE) on system efficiency. As evaporating temperature falls, the energy used to operate the refrigeration plant goes up. In addition, the size of compressor required to perform a given level of cooling also goes up as TE falls.

The refrigeration cycle has been modelled based on a set of standard parameters. All parameters except TE have been held constant for each calculation. The calculations have been carried out using industry standard thermodynamic modelling. For the carbon saving calculations above, the following refrigeration cycle assumptions were used:

- ◆ Two stage cycle, with optimum interstage pressure
- ◆ Refrigerant: ammonia
- ◆ Compressors: 75% isentropic efficiency
- ◆ No superheat or sub cooling
- ◆ TC = 22°C (TC - condensing temperature of ammonia. 22°C is an average value; it will be higher in summer, lower in winter)
- ◆ 1000kW cooling duty

The evaporating temperature (TE) was modelled at 2 deg C intervals for values between -26°C and -40°C.

The power was calculated for a nominal cooling duty of 1,000 kW.

We also calculated the swept volume of the high stage and low stage compressors for each TE.

The efficiency of the cycle is characterised by the Coefficient of Performance, COP, which is the ratio of the cooling duty divided by the power consumed.

Table 1 Calculation of power savings at different evaporating temperatures

| Evaporating temperature | Power for 1000 kW cooling | Coefficient of Performance | Extra power compared to TE = -26°C | Compressor swept volume for 1000kW (low stage plus high stage) | Extra compressor swept volume compared to TE = -26°C |
|-------------------------|---------------------------|----------------------------|------------------------------------|--|--|
| TE °C | kW | COP | % | litres/sec | % |
| -26 | 295 | 3.39 | n/a | 949 | n/a |
| -28 | 311 | 3.21 | 5.4% | 1053 | 11.0% |
| -30 | 328 | 3.05 | 11.2% | 1137 | 19.8% |
| -32 | 346 | 2.89 | 17.3% | 1228 | 29.4% |
| -34 | 364 | 2.75 | 23.4% | 1331 | 40.3% |
| -36 | 382 | 2.62 | 29.5% | 1443 | 52.1% |
| -38 | 401 | 2.49 | 35.9% | 1571 | 65.5% |
| -40 | 421 | 2.37 | 42.7% | 1711 | 80.3% |

Table 1 clearly shows how sensitive the efficiency of a refrigeration plant is to falls in evaporating temperature (the 2 key columns have been shaded).

It is also interesting to note that the extra compressor volume required is even more significant. This is because the density of ammonia at -40°C is very low and very large compressors are required. It is common practice to put a cold store on the same system as a blast freezer to reduce the cost and complexity of the plant. However, this can require a significant extra investment in compressor hardware.

4. DATA LOGGER TRIALS

In order to get a true picture of the temperatures that frozen food is exposed to in the supply chain, we tracked the temperature for eight different products using carefully placed data loggers. This section outlines the data logger trials, covering the products tested and the trial set up.

Each company was supplied with 8 identical data loggers to record the temperature of product in different positions of a standard pallet of product. Two identical pallets were used in each trial to check for repeatability of results. Each pallet was fitted with 4 data loggers.

The first trial was carried out in August 2008, with data recorded over a 5 to 10 day period. A second trial was carried out in October / November using an identical procedure and identical products to try and identify any difference caused by the ambient weather conditions.

4.1 Companies and products in data logger trials

Trial participants were chosen to reflect a range of company sizes (1 small, 3 medium sized and 4 large companies) and to be representative of the industry across a range of product categories from ice cream through to vegetables. The eight food manufacturers selected were all BFFF members.

Table 2: Manufacturers and Logistics Service Providers in BFFF trial

| Company Name | Product For Trial | Company Size | Logistics Provider | Supply chain |
|-------------------------------------|----------------------|--------------|------------------------------|--|
| Bernard Matthews Foods, Saxmundham | Golden Drummers | Large | Yearsley Chesterfield | BM cold store then Yearsley cold store |
| Greencore Frozen Foods, Leeds | Yorkshire Puddings | Medium | N/A | Greencore cold store then directly sent to supermarket RDC |
| Headland Foods, Grimsby | Chicken Curry & Rice | Large | Yearsley Heywood | Direct dispatch to LSP (HF has no cold store) |
| Lockwoods, Ambergate | Mushy Peas | Small | Reed Boardall, Boroughbridge | Lockwoods cold store then RB cold store |
| Lyons Seafoods, Warminster | King Prawn Bags | Medium | TDG Eastleigh | Lyons stand alone cold store then TDG cold store |
| Moy Park, Sleaford | Portioned Poultry | Medium | QK Cold Store, Marston | Packed in 0°C chiller room then stored in QK Cold Store. |
| R & R Ice Cream UK, North Allerton | Vanilla Ice-Cream | Large | Reed Boardall, Boroughbridge | No R&R cold store – direct dispatch to RB. |
| Schwans Consumer Brands UK, Preston | Twin Pack 5" Pizzas | Large | Reed Boardall, Boroughbridge | Brief storage in Schwan's cold store then to RB. |

4.2 Trial set up

Setting up and running the data logger trials relied heavily on the commitment of the food manufacturers to place the loggers in their pallets and on the logistics providers to locate and return the loggers at the end of the trial. In order to ensure a consistent

trial between different pallets and supply chains, we provided clear step by step instructions to manufacturers and LSPs. The main steps for the trials were as follows:

- ◆ The agreed trial product was used in a pair of trial pallets, and for both the August and the October/November trial.
- ◆ Enviros activated the temperature recorder in each logger and send it to the host company, with each logger labelled according to the required pallet position.
- ◆ The arrival of the loggers was planned to coincide with the day that the host company was producing the agreed trial product.
- ◆ The host company attached the loggers to the pallet following the blast freezing and immediate packaging of the trial product onto pallets.
- ◆ The loggers were inserted into two different boxes within the pallet (see diagram in Figure 2), with the positions shown in the figure below.
- ◆ Trial pallets were clearly labelled and the pallets placed “on hold” so they were not accidentally dispatched to supermarkets with the loggers still inside.
- ◆ Food manufacturers and LSPs probed the pallets a total of three times to record spot temperatures (1) before dispatch to LSP, (2) on arrival at LSP, and (3) just before the trial ends. This was to reflect the testing process used by supermarkets at the final delivery stage.
- ◆ Companies participating recorded the time of each supply chain movement and provided detailed feedback on their cold storage process and temperatures in a questionnaire.
- ◆ The packaging arrangements for each of the 8 trial products were all slightly different – each company placed loggers in a “practical” position closest to those shown in Figure 2.

The data loggers used were kindly supplied for use in the BFFF Trial free of charge by Gemini Dataloggers⁷. The logger used was a Tinytag Transit TG 3080. It is BSEN 12830 compliant, takes 8000 readings and has a user-programmable logging interval. A total of 64 loggers made 2 round trips during the project. All performed very well and were safely returned (even from one pallet that accidentally was sent to Romania!).

⁷ Further details available on: www.tinytag.info

Figure 2 Placement of data loggers within the pallet

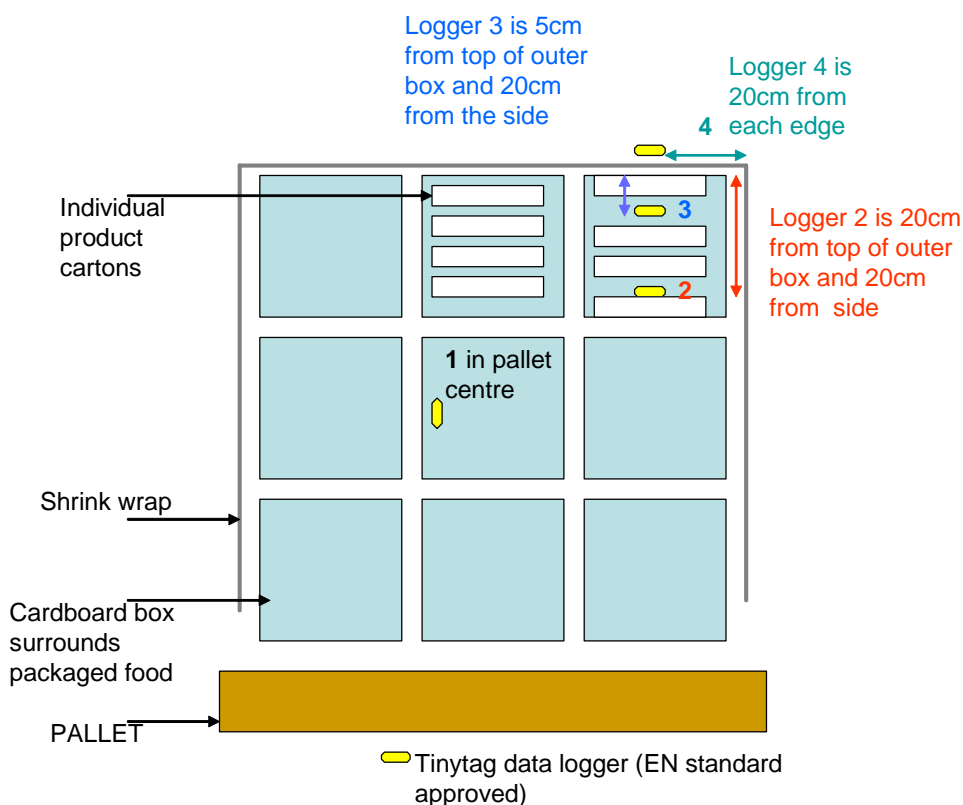

4.3 Temperature data from trials

Following each trial, the loggers were returned to Enviros and the temperature data was downloaded into a spreadsheet. Graphs showing the temperature profile of the 4 loggers on a pallet were produced.

An example graph is shown in Figure 3 below. The graph has 4 profiles – one for each of the loggers fitted as shown in Figure 2. In the example the dates on the x-axis show that the trial ran for 20 days, from August 7th to 27th. The graph shows 3 stages in the cold chain:

- Storage in the host cold store.
- Transport to the LSP.
- Storage in the LSP cold store.

Temperature probe 4 (light blue) is the one on top of the pallet – it is measuring the local air temperature rather than the product. Probes 2 and 3 are in a box of product near the outside of the pallet. Probe 1 was located in the most central box in the pallet.

One of the most interesting findings of the trials is the very slow change in temperature at the centre of the pallet. Whilst the air temperature in the store was around -22°C, Probe 1 takes nearly 20 days to fall slowly from a packing temperature of -10°C to around -20°C. In the example in Figure 3, the inner products are above -18°C for about 15 days.

Figure 3: Example of a Pallet Temperature Profile

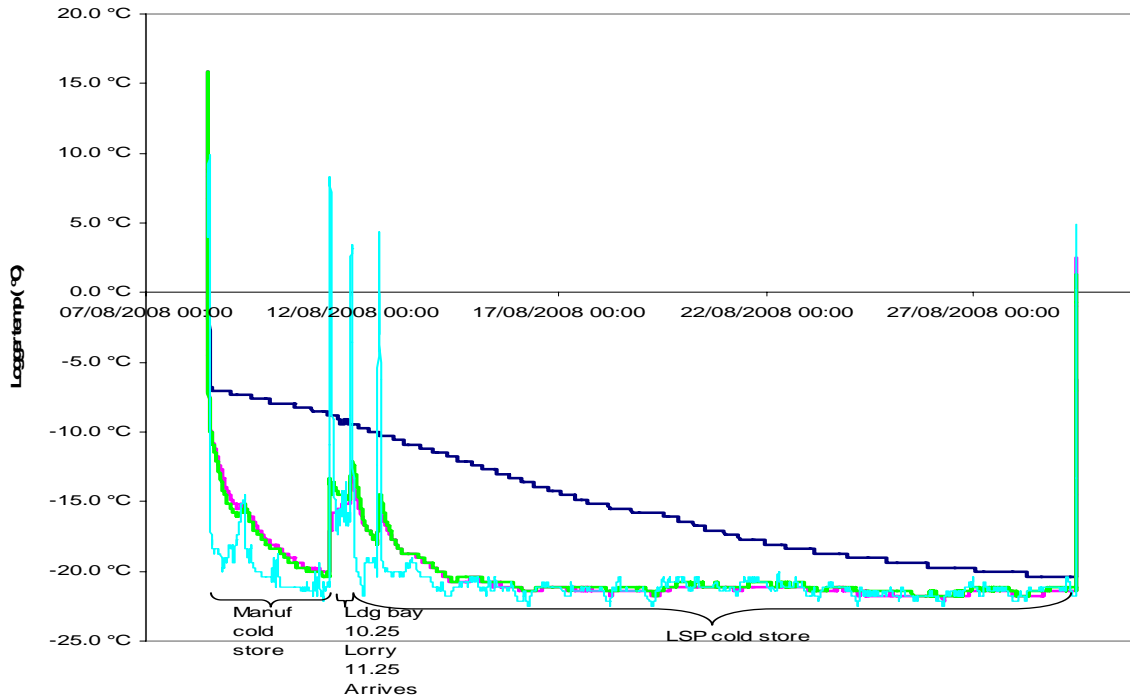

To better understand the changes taking place around the date that the pallets were moved by lorry from the manufacturers' cold store to the LSPs we have also produced "zoom" graphs that focus on this time period, as illustrated in Figure 4.

Figure 4: Example of a "Zoom" Profile

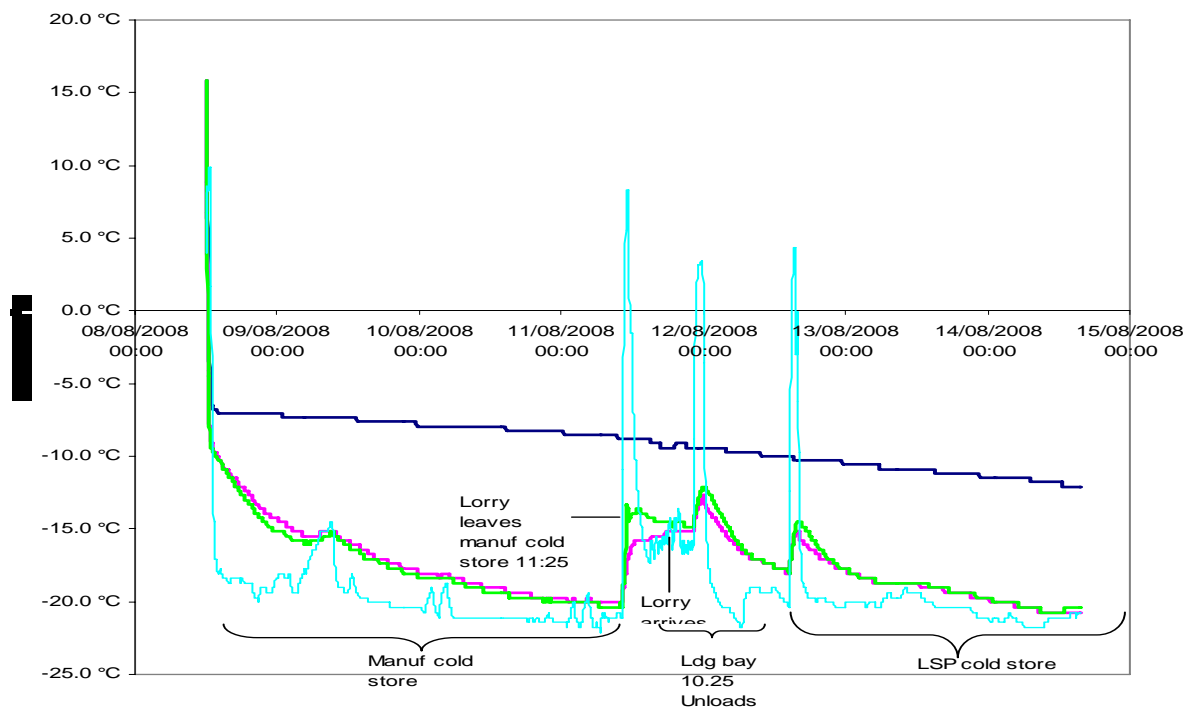

The Zoom Profile provides a much clearer picture of the fluctuations that occurred during pallet transportation. The inner most products are “unaware” of the transportation phase of the chain. The air temperature (Probe 4) fluctuates significantly, but probes 2 and 3 (in an outer box) do not rise above -10°C at any point. In this example we see that the air temperature in the lorry was only being controlled at around -15°C . This is unusual – in most of the trials the lorry was held at a lower temperature.

4.4 Other data collected

The companies involved in the trial supplied 2 other types of information:

- a) They kept an event record and did “manual” temperature readings with a hand held probe. This information was used to properly understand the data logger profiles.
- b) They completed a questionnaire with data about their cold store. This data was used in conjunction with the temperature profiles to help identify and quantify the energy saving opportunities.

4.5 Control of Evaporating Temperature

It is very important to understand the link between cold store air temperature, T_A , and the refrigeration plant evaporating temperature, T_E . Some key points are as follows:

- a) T_E must always be lower than T_A . This is to allow unwanted heat to flow from the cold store air into the evaporating refrigerant that is cooling the store.
- b) A small temperature difference between T_A and T_E is favourable in terms of energy efficiency as leads to a lower temperature lift.
- c) The temperature difference between T_E and T_A is related to the plant design and to the method of control.
- d) In terms of design, a key parameter is surface area. If a store is large evaporators then the temperature difference between T_A and T_E will be smaller than for a store with small evaporators.
- e) In terms of control, the temperature difference depends on the control methodology.
- f) Small cold stores often use a refrigeration system based on a DX (direct expansion) control system. In these circumstances there is no direct control of T_E . A thermostat is used to control T_A and T_E “floats” up or down to achieve the T_A required.
- g) However, none of the 13 refrigeration systems in this project work in this way. For larger stores it is most common to use a pumped circulation system as illustrated in Figure 5. The cold store air temperature (T_A) is controlled by a thermostat (TC) located in the cold store. Usually this switches a solenoid valve that controls flow of refrigerant to the evaporator. The evaporating temperature (T_E) is controlled independently by a pressure controller on the low pressure surge drum (PC). This controls the capacity of the compressors operating to maintain a specific pressure in the surge drum. T_E is the saturation temperature equivalent to the surge drum pressure. The system also has a level control (LC) that controls the flow of refrigerant from the condenser to the surge drum.
- h) With the type of control system described above and illustrated in Figure 5 it is possible that T_E is much lower than it needs to be. T_E is often set “conservatively”

to avoid problems such as excessive frost build up or peak heat loads. Under many circumstances T_E could be set at a higher level, but few refrigeration plant control systems have the sophistication to ensure that T_E is at the highest possible level at all times.

Figure 5 Typical Cold Store Configuration

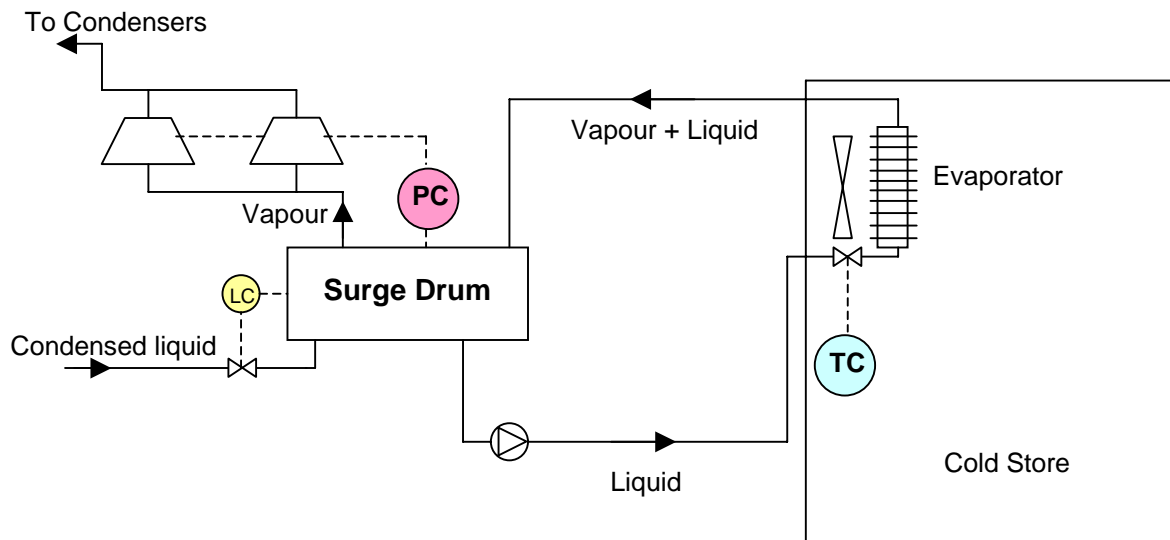

4.6 Assessment of Energy Saving Opportunities

The temperature graphs and the other data collected from project participants were carefully analysed to identify a number of specific energy saving opportunities. A total of 37 recommendations were made to the 13 companies that took part in the trial.

These recommendations were then split into groups of similar measures that could be applied at other manufacturing and cold storage sites in the industry. It was found that there were 8 generic recommendations from the project. These are described in Chapter 5 of this report.

5. SUMMARY OF PROJECT RESULTS

5.1 Introduction

This project has involved an analysis of cold storage at 8 food manufacturers and 5 logistic service providers (LSPs).

Each of these 13 organisations has provided BFFF with background information about their refrigeration systems and has taken part in a detailed evaluation of temperatures on pallets of food held in both manufacturer and LSP cold stores. Temperature trials took place in peak summer conditions (August 2008) and cooler autumn conditions (October / November 2008).

In this section of the report we summarise the key findings of the project.

5.2 Overall CO₂ Savings

The recommendations given to the host sites included a total of 37 different projects that could be implemented at the 13 sites involved in this project.

The total saving potential identified is 4,800 tonnes CO₂ per year.

Significantly higher savings can be achieved if the project results are replicated by other similar factories in the food industry.

5.3 General Findings from Host Questionnaires

A number of general issues were identified from the questionnaires completed by each company during the project. These are as follows:

- a) **Lack of energy sub-metering.** There was a notable absence of sub-metering used on the refrigeration systems at any of the 13 sites. Despite average site energy bills of over £0.5 million per year none of the sites use kWh meters on their refrigeration systems to monitor and improve performance. The lack of metering represents a missed opportunity to identify and achieve energy savings. It also makes estimation of energy saving potential in this project difficult.
- b) **Lack of seasonal control.** There was a general lack of “sophistication” in the control regimes used for items such as suction pressure, defrost frequency and evaporator fans. Many sites did not change operational set points between summer and winter time.
- c) **Similar technologies in use.** There were great similarities between the equipment used. Many stores used single stage economised screw cycles with ammonia refrigerant and evaporative condensers. 9 out of 12 sites used ammonia. The other 3 used R22 (which is due for phase out under the EC Ozone Regulations). 11 out of 12 systems were pumped circulation with suction pressure control of compressor capacity. One system used a low temperature secondary refrigerant (Tyfoxit) to provide cooling to the cold store.

5.4 General Findings from Temperature Trials

The project has generated some very useful data about the temperature profile of food products during storage and transport.

A critical finding is the difference in the temperature profile achieved by products stored at the centre of a pallet and products near the outside edge. In most cases

products were frozen in blast freezers to around -10 to -15°C. Products near the centre of a pallet could take between 1 and 2 weeks to achieve -18°C, whereas the products near the edge achieved this temperature within 1 to 3 days.

It was common to see significant air temperature variations in many of the cold stores. These were usually cyclic in nature, being linked to defrost regimes and tariff management regimes as well as the characteristics of temperature control devices. Products in the centre of pallets were totally “unaware” of these air temperature changes and even the products very near the edge of a pallet often showed little temperature variation (this was product specific – some products were more sensitive to air temperature changes).

Two identical pallets of product were used for each trial to check for consistent results. In most cases there was little difference in the data recorded for each pair of pallets, although in one trial the pallets showed significantly different variations in air temperature; this showed that position of pallets in a cold store can have an impact on temperatures achieved.

5.5 Specific Findings from Trials

The temperature recording trials have provided the industry with some very useful information about opportunities to improve the performance of the cold chain. The analysis given in Section 3 of this report highlights the importance of running a cold store with the highest possible evaporating temperature. For example, if the evaporating temperature can be raised by 4 deg C from -32 to -28°C, an energy saving of about 11% can be achieved. The trials showed significant opportunities to raise evaporating temperatures.

The 37 specific projects identified in the study each fall into one of 8 opportunities which are discussed in the following sections.

5.5.1 Raising of Cold Store Air Temperature

Some cold stores were run at unnecessarily low temperatures. Four of the manufacturers cold stores were being operated several degrees colder than the store to which products were subsequently sent.

There was also potential for raising the temperature of the air at 2 of the LSP cold stores. Some stores were controlling at an average temperature of -22°C, whilst others were successfully operating at -20 or -19°C.

A simple adjustment to the store control system can provide good savings. It is also vital to make an equivalent adjustment to the suction pressure control – otherwise no saving will be made! Figure 6 illustrates the relevant data from one of the trials. The suction pressure in the manufacturer cold store can be raised by about 6 deg C, which would give an energy saving of over 15%.

Figure 6: Unnecessarily Low Store Temperature Set Point

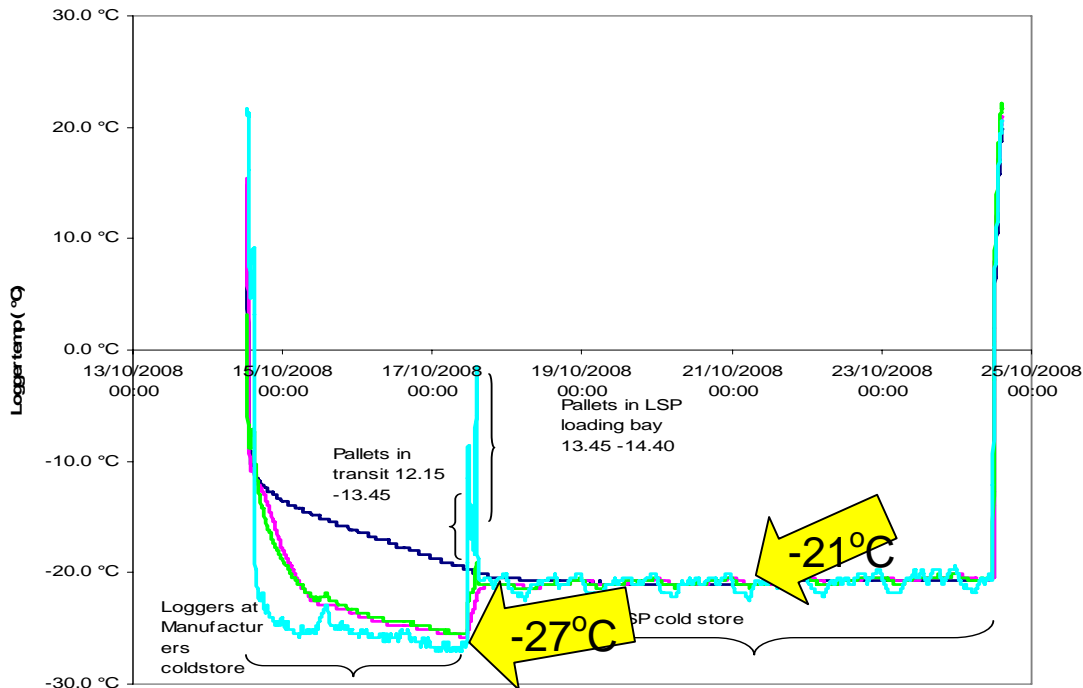

A key finding of this project is a general level of conservatism regarding temperatures in the cold chain. If we wish to minimise CO₂ emissions it is necessary to run more closely controlled operations that will allow warmer storage temperatures. It may be necessary to challenge the importance of -18°C, which was probably chosen because it is equal to 0°F.

5.5.2 Reduction of temperature difference between air and refrigerant

The evaporating temperature of 2 plants was excessively low compared to the air temperature. Whilst the store temperature was reasonable, at around -21°C, the evaporating temperature was -36°C and -40°C respectively. These are unnecessarily low and are probably a result of over-cautious maintenance.

Efficient cold stores can operate with a 7 or 8 deg C difference between the evaporating temperature and the air temperature. All store operators should try to raise the suction temperature control system to the highest possible value.

5.5.3 Seasonal adjustment of evaporating temperature

None of the companies involved in the project said that they make any seasonal adjustment to evaporating temperature settings. This is a missed opportunity as the cooling load on a cold store is lower in winter than in summer. A 1 or 2 deg C increase in suction temperature may be easily achievable, especially if combined with use of variable speed drive fans and a flexible defrost regime.

5.5.4 Avoiding air temperature fluctuations

One of the best cold stores in the trial showed it is possible to have a very steady air temperature, with fluctuations of less than +/- 0.5 deg C. Other stores had large variations in air temperature, sometimes in the range of +/- 3 deg C. This degree of temperature fluctuation is potentially wasteful. Steady temperature control at the warmest temperature possible is preferable.

Figure 7: Excessive Store Air Temperature Fluctuation

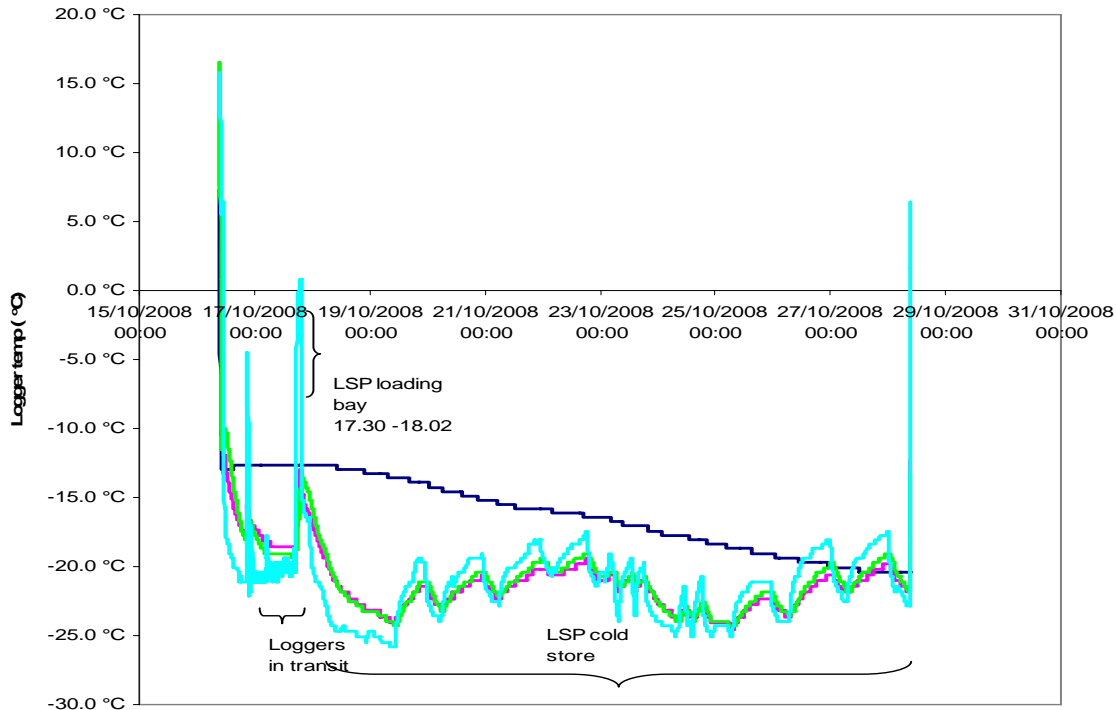

In figure 7 we can see a store fluctuating in temperature between -25°C and -18°C. If it ran at -18°C all the time the suction temperature could be raised by 7 deg C, with an energy saving of nearly 20%.

The only exception to this is when night rate electricity can be successfully used to “over-cool” the store when electricity is cheap. The strategy for doing this should be carefully examined – in more than one case we found a company still used a night time cooling regime even though their tariff had changed to a flat rate!

If night time overcooling is carried out for tariff purposes it is important that you adopt a 2-level suction temperature control strategy. During the night period the suction temperature controller can be set to a lower value to achieve more cooling. Outside the night period it is vital to raise the suction temperature control set point as high as possible.

5.5.5 Splitting Blast Freezers and Cold Stores

2 of the stores in the trial had a blast freezer and a cold store on the same suction line. This leads to “lowest common denominator cooling”. The blast freezer needs a low evaporating temperature (e.g. -40°C is common) so the cold store needs to use that temperature level, even though -30°C or higher would be sufficient. This is clearly very

wasteful, especially if the blast freezer operates for a significant proportion of the week.

To split the systems does require a major investment in extra compressor/s, surge drum, pipework and controls. For new plants the economic case is usually compelling as it is easy to accommodate this option at the design stage. Existing plants may have constraints, but this option should be fully evaluated if it is relevant.

5.5.6 Avoiding over-cooling in blast freezers

4 out of 8 manufacturers cooled their product in the blast freezer to a temperature below that of the cold store. This is wasteful and can be avoided by better temperature control.

In one case the freezing was done with liquid nitrogen. This is an especially expensive and energy intensive way of freezing, so it is vital to minimise the freezing done with nitrogen and maximise what is done subsequently in the cold store.

In figure 8 we have shown the temperature trace for a product that was frozen to -30°C and then placed in a cold store at around -20°C .

Figure 8: Overcooling in Blast Freezer

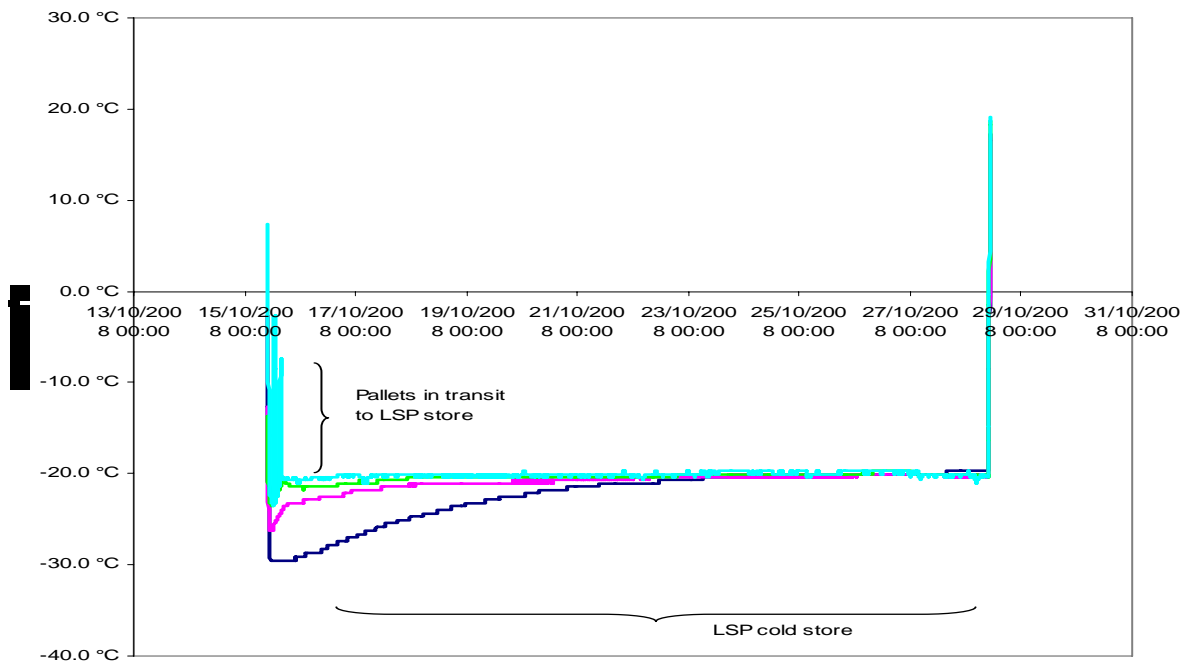

5.5.7 Using variable speed drive fans

The fan control regimes used in most of the trial cold stores is relatively crude, either with 24/7 fan operation or some form of on/off control (often manual switching).

A better option is to use a variable speed drive on each bank of evaporator fans. It is better to run fans constantly at slow speed than to use on/off control. Fan power consumption follows a “cubic relationship” with flow rate. This means if you slow the fan to give 80% flow it only uses 50% power. If you reduce flow further to 50%, the power usage falls to 12.5%. Using a fan at low speed ensures the evaporator is still being used – unlike on/off control when the evaporator surface is “wasted” whilst the fan is off.

It is important to note that fans represent a significant proportion of the overall heat load in a store – especially in winter time when fabric load and air infiltration load is well below the peak summer time values. Hence you don’t only save fan power – you also save the compressor power needed to remove the heat generated by the fan.

Slowing fans down can provide excellent savings and also help with the strategies to raise evaporating temperature to the highest practical level.

5.5.8 Ensuring a flexible and effective defrost system

Most of the stores in the project did not have a flexible defrost regime, in terms of frequency and length of defrost. In winter time air holds about 30% of the moisture that it holds on a warm summer’s day. Also, the rate of air flow through an open doorway is slower in winter, as it is proportional to the temperature difference between the air inside the store and the air outside. Taking these 2 effects into account it is likely that the rate of frost formation in winter time is less than a quarter of the rate that occurs in summer.

Many defrost control regimes are based on “worst case scenario”, which is the summer time requirement. In winter a different regime can be adopted. This will reduce the heat entering the store during a defrost cycle and avoid such large temperature variations.

Most of the trial sites had defrosts at least once per day. One had 4 defrosts per day (and major temperature fluctuations observed by our loggers). The most common length of defrost was 45 minutes. Few of the stores indicated a different defrost regime in winter. The best store, in terms of defrost regime, stated:

“Cooler defrosts are individually tailored to their own requirements. From once a week to twice a week, to some with no set programmed defrosts. Defrost cycle 30 minutes.”

This store had also made significant efforts to minimise air ingress through good door arrangements and a chilled and dehumidified loading area.

6. CONCLUDING COMMENTS

This project involved an investigation of cold store temperatures and refrigerant evaporating temperatures at 8 food manufacturers and 5 logistic service providers. The investigation identified good opportunities for energy efficiency improvements at all 13 sites. Some of the key findings of the project are as follows:

1. Refrigeration plant efficiency is very sensitive to the “temperature lift” of a plant (this is the difference between the condensing temperature and the evaporating temperature. A 1 deg C reduction in temperature lift will typically save 2% to 3% in energy consumption.
2. Temperature lift can often be reduced by lowering the condensing temperature, especially outside the peak ambient conditions occurring in summer. There are several ways of achieving this, but this topic was beyond the scope of this project.
3. This project concentrated on looking for improvements related to raising the evaporating temperature.
4. It is important to recognise that the evaporating temperature is usually set in conjunction with a “suction pressure control system” that controls compressor capacity to maintain a specific level of suction pressure (and hence evaporating temperature).
5. The project identified 8 types of opportunity to improve cold chain efficiency. These are described in Chapter 5 and include:
 - a) Raising of Cold Store Air Temperature
 - b) Reduction of temperature difference air - refrigerant
 - c) Seasonal adjustment of evaporating temperature
 - d) Avoiding air temperature fluctuations
 - e) Splitting Blast Freezers and Cold Stores
 - f) Avoiding over-cooling in blast freezers
 - g) Using variable speed drive fans
 - h) Ensuring a flexible and effective defrost system
6. Measures of this type can easily be replicated at other frozen and chill installations in the UK. Savings of over 10% will often be achievable with relatively little capital investment. Even larger savings of over 20% can be achieved in some situations.
7. The use of electricity sub-metering in all 13 plants investigated was almost non-existent. Better use of electricity metering is vital if plant operators are to identify and justify the best energy saving opportunities.

CONTACT DETAILS:

BFFF
Warwick House, Unit 7
Long Bennington Business Park
Main Road, Long Bennington
NEWARK, NG23 5JR

Tel: 01400 283090
Email: hazelcranidge@bfff.co.uk
Web: www.bfff.co.uk

Brian Young, Director-General

The Carbon Trust
6th Floor, 5 New Street Square
LONDON
EC4A 3BF, U.K.

Tel: 020 7170 7000
Web: www.carbontrust.co.uk

Low Carbon Collaboration Delivery Manager

Enviros
Telegraphic House
Waterfront Quay
Salford Quays
MANCHESTER
M50 3XW, U.K.

Tel: 01932 866 344
Email: ray.gluckman@enviros.com
Web: www.enviros.com

Ray Gluckman, Consulting Group Director